

Screwdriver modules SEL Series

with automatic screw
feeding

well suited for many
applications!

Simple
Flexible
Economical
Easy servicing

For automatic assembly

- Series production
- Recordable quality

Applications

- Manual work stations
- Transfer lines
- Rotary table machines
- Suitable for short screw driving times

Advantages

- Individual and customized solutions realized quickly and easily
- Nose piece set up for your application
- Simple sensor adjustment
- Rotatable screw head
- Various mounting positions

Easy servicing

- Simple correction of faulty function
- Tool change < 30 seconds
- Automatic screw rejection when screw operation faulty



SEL with electric motor

Technical details

- Automatic screw feeding
- Operates with two slides - delivery stroke unit and tool-bit/motor
- Two stroke sizes
- Electric or pneumatic drives
- Short and compact construction
- Identical basis modules for different screw sizes and torque ranges

Layout

- 1 Drive unit (electric or pneumatic)
- 2 Tool/bit return indicator (start position)
- 3 Tool/bit depth control
- 4 Screwdriving head return indicator
- 5 Mounting face
- 6 Feed tube
- 7 Screw loading control
- 8 Screwdriving head

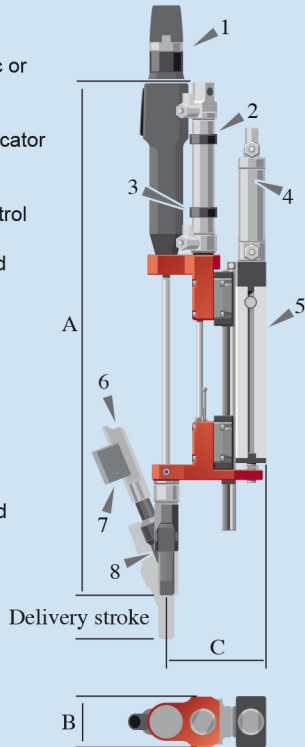

SEL with feed and control unit ZSE



Feed and control unit ZSE

Technical Data	SEL 20	SEL 100
Screw head dia. max. (mm)	5 - 12	5 - 20
Torque max. (Nm)	0,2 - 20	5 - 100
Delivery / Tool stroke	40 / 80	80 / 180
Pressure (N/6bar)	40 - 180N	100 - 250N
A (mm)	ca. 500	ca. 700
B (mm)	50	80
C (mm)	100	155



Selection of screw types

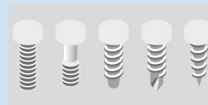

Selection of thread types

Control functions

- Start position of tool stroke and delivery stroke units
- Torque
- Screwdriving depth
- Screwdriving cycle OK/Not OK
- Screw loading control



STÖGER
AUTOMATION

STÖGER AUTOMATION GmbH · Gewerbering am Brand 1 · D-82549 Königsdorf

☎ +49(0)8179/99767-0

☎ +49(0)8179/99767-50

✉ info@stoeger.com

Internet www.stoeger.com